



DESIGO™ I/O-OPEN

WILO interface module PTM50.32V01

for four electronically controlled WILO-heating pumps

Interface module enabling communication between intelligent heating pumps featuring WILO-interfaces (current-driven) and automation stations with P-bus connection. Connecting four pumps via separate interfaces or two twin pumps via a joint interface.

Use

Integrating pumps that are capable of communicating into process systems in the field of heat generation and distribution as well as district heat:

- Online communication between WILO-pumps and Siemens Building Automation automation stations.
- The interface module can be connected to automation stations with P-bus which support the interface module on the software side. Refer to "Equipment combination".

Functions

Interface between the WILO-interface and the Siemens Building Automation P-bus (process bus).

Signal transmission

The following information is transmitted between the automation station and the pump:

From automation station to pump

- Control of operating mode ON/OFF and Min-ON
- Setpoint for pump head 0...100 m

From pump to automation station

- Operating data encoded
- Fault status data encoded
- Pump head [m]
- Flow rate [m³/h]
- Delivery rate [W]
- Pump speed [r.p.min]

Access

This data can be accessed as follows:

- locally at the automation station and
- centrally via the PC user interface of the building automation and control system

Note

The range of values for the operating parameters is illustrated in table 1 under the heading "Technical design"; table 2 lists the encoded contents for operating and fault status messages.

Functions relating to application

Communication between the pump and the automation station serves to link heating and pump control. Using the transmitted data and variables as the basis, the following functions can be generated via the automation station:

- Adapting the pump output to the various building occupancy hours using time switch programs
- Visualizing pump parameters and generating trend charts
- Adapting the pump output to the operating status of the heating boiler
- Optimizing heating control by acquiring the pump's flow rate
- Controlling the primary pump in dependence of heating circuits connected in series
- Energy management to optimize energy usage and efficiency
- Matching the pump's output to the currently required flow rate, e.g., by registering usage via electronic heat meters
- Central acquisition of operating statuses to include archiving and trend indication
- Central acquisition of faults including service staff instructions
- Central maintenance management using the number of operating hours
- Integrating electric peak load limiting through registering power consumption
- Remote signaling and monitoring via modem and radio or public telephone lines

Display functions on the interface module

P-bus and WILO-interface both offer one LED for operating and error messages each.

Operational safety

All safety and precautionary measures regarding function and system safety are listed under "Technical design".

Type summary

Interface module WILO

PTM50.32V01

Delivery

Base and electronic module are delivered together, however in separate boxes that are attached to each other.

Accessories

Refer to data sheet N8105 for general I/O module accessories which must be ordered separately

Equipment combinations

Automation stations	The interface modules can be connected to automation stations with P-bus which support the I/O functions on the software side. Refer to table 1 of section "Technical design" and to document Z8102, "I/O module system" or data sheet N8100 "I/O module range".
WILO heating pumps	Used with pumps that are capable of communicating with the WILO-interface (type series TOP-WILO with electrical current interface). Refer to the respective pump manufacturer's technical documents for detailed information.

Technical design

General	The interface modules allows for mapping pump data points to the P-bus so that the automation station is able to describe or read each data point via the assigned addresses and channels. The module acts as data concentrating unit in the direction of the WILO-interface and exchanges data point information with the pumps using serial telegrams. Acting in the other direction, the module displays the information on the P bus so that the automation station is able to read the information.
Generating a program	With regard to functions, the interface module contains eight I/O modules, based on four special module types. These modules are "unreal", meaning they do not exist as individual modules. When configuring a plant, the associated I/O functions must be called up and instantiated. Table 1 contains the data types with the required settings and assignments for the values (parameter). For module types, refer to "Connection diagrams", and for P-bus address assignments, refer to "Addressing".

Data traffic

P-bus	Data traffic between interface module and automation station takes place on the 3-wire P-bus (Process bus). Refer to data sheet N8022 "Process bus" for detailed information on the P-bus.
WILO-interface	Pump data is exchanged bi-directionally using electrical current interfaces between the WILO-interface module and the pumps. For technical information, refer to the chapter on technical data.

Addressing

Offset address	Each data point type (e.g. pump head, pump speed) in a module has its own fixed address (offset address: 0 ... 7). The channel numbers used for pump selection allow for connecting several pumps per module. Pump 1 is assigned to channel 1, and pump 4 to channel 4. Refer to table 1 in this section for selection and special features with regard to addressing.
Base address	Using an address plug, a base address is assigned to the module (hardware address). In the module, fixed offset addresses are used. With this interface module, the base addresses are assigned in increments of 16.
Relative I/O address	The complete address (relative I/O address) for an input or output is illustrated with the following example: Base address (17) + offset address (5) and channel number (.1) = relative I/O address (22.1). Refer to table 1 for additional information.

Table 1: Settings to generate module functions

The table below shows data point or module type assignments to the internal offset addresses used to determine the relative P-bus addresses.

relative P-bus-Address: Basis- ¹⁾ + Offset address	Example (PRU) with base address1 Address Channel		Data point P1 = Pump 1 P4 = Pump 4	Range of values	Unit	Funct. block type	Module type ²⁾	Slope
Base address + 0	1	Channel 1 to Channel 4	Switching command P1 to Switching command P4	0 = OFF ⁴⁾ 1 = ON 2 = MIN-ON	—	StepO-Intfc	PTD1.4DOS	—
Base address + 1	2	Channel 1 to Channel 4	Setpoint pump head P1 to Setpoint pump head P4	0...100,0	m	ModIO-Intfc	PTD1.4AOS	10
Base address + 2	3	Channel 1 to Channel 4	Operating code P1 to Operating code P4	0...7 ³⁾	1	BinI-Intfc	PTD1.4DIS	—
Base address + 3	4	Channel 1 to Channel 4	Operating code P1 to Operating code P4	0...4 ³⁾	1	BinI-Intfc	PTD1.4DIS	—
Base address + 4	5	Channel 1 to Channel 4	Pump head P1 to Pump head P4	0...100,0	m	ModII-Intfc	PTD1.4AIS	0,1
Base address + 5	6	Channel 1 to Channel 4	Flow rate P1 to Flow rate P4	0...400,0	m ³ /h	ModII-Intfc	PTD1.4AIS	0,1
Base address + 6	7	Channel 1 to Channel 4	Delivery rate P1 to Delivery rate P4	0...4000	W	ModII-Intfc	PTD1.4AIS	1
Base address + 7	8	Channel 1 to Channel 4	Pump speed P1 to Pump speed P4	0...4000	r.p.min	ModII-Intfc	PTD1.4AIS	1

¹⁾ All base addresses can be used between 1...241 in increments of 16 (e.g. 1, 17, etc.).

²⁾ These module types are "unreal", i. e. they do not exist as individual modules.
Load units: 8 at 12,5 mA each (independent of used data points)

³⁾ see table 2 (Column "Encoded message")

⁴⁾ 0 = pump OFF; 1 = Normal speed ON; 2 = Minimum speed MIN-ON

Table 2: Operating and fault status data messages

The table below lists the encoded messages and their meaning as they appear on the automation station or the screen. Each message is displayed in the form of a digit (= Bit position).

Message type	Encoded message (Bit position)	Bit-status and interpretation		Designation
		Bit set (1)	Bit not set (0)	
Operating data	1	ON	OFF	Operating message
	2	Left	Right	Rotation direction
	3	Deviation	No Deviation	Set/Actual deviation
	4	OFF	ON	Pump via external switch
	5	Twin pump	Single pump	Pump type
	6	Manual	Automatic	Pump Man./Aut.
	7	Invalid values (cannot be determined)	Valid values	Flow rate (Q) and pump head (H)
	8	Minimum speed	Normal speed	Speed
Fault status data	1	Yes	No	Module fault
	2	Yes	No	Engine fault
	3	Yes	No	Communication error
	4	Yes	No	Pump fault
	5	Fault	No fault	Supply voltage

Table 3: Module displays for P-bus and WILO-interface

The two LEDs for P-bus and WILO-interface indicate the operating status of module and bus connections. The table below provides all possible interpretations.

Phase	P-bus LED 1 (I)	WILO-interface LED 2 (II)
Interpretation		
Start phase (approx. 5 s)	Permanently lit Normal status	
	Permanently off No P-bus module power supply	
	Flashing Defective module	
Operating phase (after 5 s)	Permanently lit Normal data exchange on P-bus	Permanently lit Normal data exchange on WILO-interface
	Permanently lit Normal data exchange on P-bus	Flashing A minimum of 1 WILO-interface is faulty or false pump in use (Twin pumps/Single pump)
	Permanently lit Normal data exchange on P-bus	Permanently off No data exchange on WILO-interface
	Flashing Faulty or no data exchange on P-bus	Permanently lit No faults and data exchange on a minimum of 1 WILO-interface
	Flashing Faulty or no data exchange on P-bus	Flashing A minimum of 1 WILO-interface is faulty or false pump in use (Twin pumps/Single pump)
	Flashing Faulty or no data exchange on P-bus	Permanently off No data exchange on WILO-interface
	Permanently off Not a permissible status	Permanently lit Module defective
	Permanently off Not a permissible status	Flashing Defective module
	Permanently off Reference voltage or 24 V are missing	

Note

Communication failure on the WILO-interface:

If no communication exists to any pump, then the WILO-interface LED is not lit (LED 2). With previously operating pumps, a failure is registered only after a failure tolerance period of 50 seconds.

As the pumps must communicate in a 5 second cycle, delays of 5...10 s occur until the module registers all connected pumps.

The data point "Speed" is available after another 5 s delay due to product-related differences in the protocol series transmitted by the pumps.

When the pump is starting up or when the speed has been reduced via potentiometer, pump head (H) and flow rate (Q) cannot be determined. In this case, bit position "7" is set and the maximum possible values for pump head and flow rate are transmitted. If necessary, these values can be corrected in the application software of the automation station.

System and function safety

Switch-on behavior	After switching on the power supply (reference voltage BEZ and system potential G), the modules can communicate within 0.5 seconds meaning that they are ready to receive telegrams.
Transmission reliability	<ul style="list-style-type: none">• Faulty transmission is detected and not accepted. Transmission reliability is guaranteed with the aid of safety code CRC.• An automation station must transmit updated output values in the form of an error-free telegram in 4 second intervals to the interface module. If no telegram is received within this specific period, then the module's default values are activated and transmitted to the pumps in place of non-transmitted actual values.• If the WILO-interface connection to the pumps is interrupted or when data transmission is heavily disrupted, then the pumps continue to work with default values. With regard to pump data, bit positions "7" (Flow rate and pump head) and "8" (Pump speed) are set to "0". Exception: With fault status data, bit position "3" (communication error) is set to "1".
Protection from faulty wiring	The module is not damaged, if, by mistake, AC 230 V is applied to the pump interface connections.
Short-circuit strength	The WILO-interface outputs are short-circuit proof.
Working on the module with voltage present	The module is not damaged when connecting the pump interface lines as well as plugging in and unplugging the module while voltage is applied.
<i>Note</i>	<p>The entire I/O module functionality comprises the module (hardware) as well as signal handling in the module and the automation station (software). To fully understand the module functions, the associated process sequences and configuration options for the user program must be considered.</p> <p>For the technical features common to all I/O modules, refer to document Z8102, "I/O module system".</p>

Mechanical design

Module	Module unit with plastic housing containing a terminal base and electronics, can be plugged onto the I/O bar, signal and voltage pick-off via contact springs on conductor rail in the I/O bar.
Connecting terminals	The connecting terminals for the I/O modules that are arranged on the I/O bar perform the terminal block's task. Terminal blocks must usually be installed in the control panel for external wiring. They fulfill all applicable standards and guidelines, contain the test terminal functions and can be labeled specifically for the plant.
Module front	Transparent module front for insertion of the plant-specific module labels. The specifically prepared and perforated labels are marked with the help of the engineering tool for the building automation and control system. The address plug as well as the two LEDs for P-bus and WILO-interface are located on the module front. There are no operator elements.
Accessories	Necessary I/O module accessories are listed in data sheet N8105.
<i>Note</i>	Refer to document Z8102, "I/O module system" for a detailed description of the module's mechanical design.

Front view

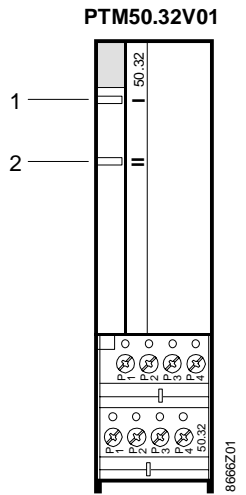

- 1 LED for the P-bus
- 2 LED for the WILO interface

Engineering notes



Document Z8102, "I/O module system", contains all system-related engineering know-how; Please read the data sheet before proceeding to the sections below and pay special attention to all safety information.

Proper use

In a system, these I/O modules must be used only for applications as described in document Z8102, "I/O module system". Additionally, all module-specific features and requirements must be observed as described on the title page (bold print) of this data sheet as well as in the chapters "Use", "Engineering notes", and "Technical data".



All paragraphs marked with the warning triangle as illustrated on the left contain additional safety information and requirements as well as safety limitations: Be sure to observe all the warnings to avoid physical injuries or damages to objects.

Interface coupling
WILO interface lines

The WILO interface is **galvanically separated** from the module's electronics. The two-core lines can be interchanged.

Module addresses

To define the P-bus address based on the base address and the offset address, refer to "Technical design".

LEDs

During start-up (5 s), the two LEDs for the P-bus and WILO interface display important diagnostic information about the module and the bus installation. In case of doubt, the start-up phase can be re-started by briefly removing and refitting the module. Refer to table 3, "Technical design", for detailed information on LEDs.

Fitting notes

Refer to document M8102, "I/O modules and P-bus".

Fitting instructions for the I/O modules on mounting rails and on the I/O bar are printed on the package.

Commissioning notes

Module address	The address plug with the base address must be fitted. Refer to "Technical design" for related requirements. The interface module has no other setting or operating elements.
Pump settings	The pumps which are capable of communicating (Types TOP-WILO with electrical current interfaces) must be assigned the pump number or the address when commissioning. Please refer to the pump manufacturer's documentation for detailed information on pump settings.
Re-wiring of running pumps	If an operating pump is connected to a different module connection, then the module must be reset by removing and refitting the module on the I/O bar.
General	General information on commissioning I/O modules is listed in document Z8102, "I/O module system".

Technical data

Power supply	Operating voltage	AC 24 V \pm 20%
	Safety extra-low voltage "SELV" or protection by extra-low voltage "PELV" as per	HD 384
	Power consumption	2 VA
	I/O module power supply via P-bus	DC 24 V (against G0)
	Load units	8 (12.5 mA each)
Module addresses	Number range for base addresses	1...241 (see table 1)
P-Bus	See data sheet 8022 "Process Bus"	
WILO interface	Interface type	WILO electrical current interface
	Insulation resistance of the galvanically separated interface in accordance with	AC 500 V EN 60730-1
	Transmission speed (baud rate)	1200 bps
	Signal level	
	logic 0	0 mA
	logic 1	10 mA
	Cable type	two-core, unscreened
Diameter	min. 0,6 mm	
Cable length	max. 500 m	
CE - Conformity	In accordance with the directives of the European Union: Electromagnetic compatibility	89/336/EEC
Note	For technical data common to all I/O modules, refer to document Z8102, "I/O Module System".	

Connection diagrams

Internal diagram

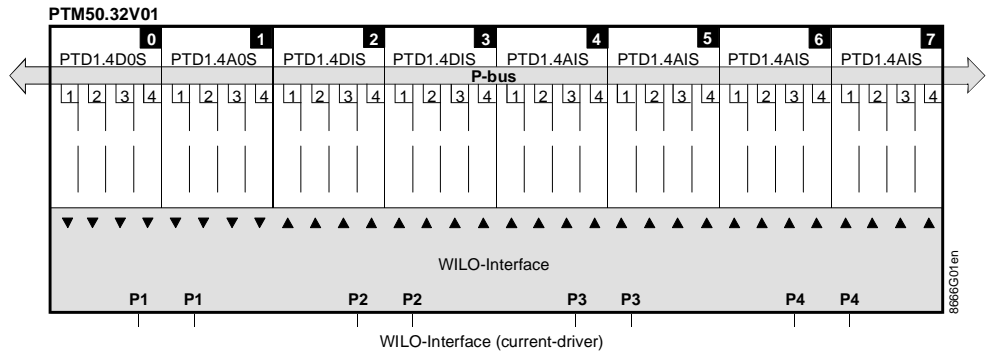

Addresses

- 0...7 Offset addresses (black squares)
- 1...4 Channel addresses within offset addresses (white squares)
(Assigning data points to the respective module types, see table 1)

WILO interfaces

- P1–P1 til Connections for heating pumps TOP-WILO
- P4–P4 (The two wires of one connection can be interchanged)

Wiring diagram

Wiring possibilities with single pumps and twin pumps

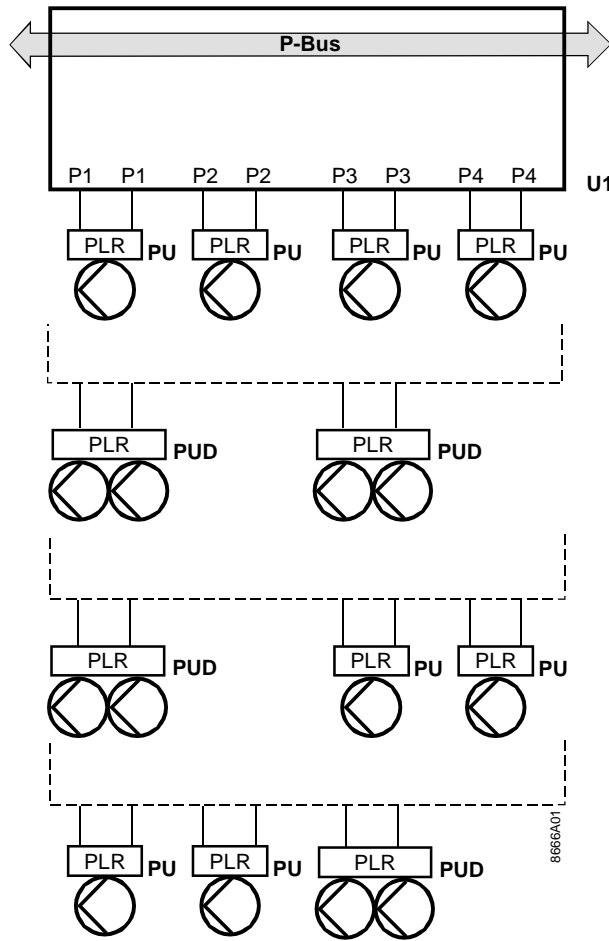

- U1** Interface module PTM50.32V01
- PU** Single pumps
- PUD** Twin pumps (permissible only for connections P1–P1 and P3–P3)
- PLR** Terminal labeling of the pump

Dimensions

Dimensions in mm

